

Prepared by:-	M.Davies	Approved by:-		Date: 09/09/14
REV NO:-	1			
ECO:-	4282			

INTRODUCTION

Hi-Force manifolds are designed specifically to allow easy control of the direction of flow of the systems hydraulic fluid. Both the HM2C and HM4C have 3/8" NPT outlet ports. Hi-Force manifold blocks provide even greater versatility in your hydraulic system. Always specify Hi-Force manifolds for use with your Hi-Force hydraulic tools.

SAFETY NOTES

MAX WORKING PRESSURE:

HM2C 700 BAR

HM4C 700 BAR.

Do not exceed the max working pressure of 700 bar.

Always ensure that any Hi-Force hydraulic hoses are correctly fitted to the manifold.

Wear suitable personal protection equipment when operating hydraulic equipment.

Keep all body parts away from cylinder and work piece / load

MANIFOLD SETUP AND OPERATION

1. Ensure that all ports are clean and free of debris prior to connecting any hoses. Always use PTFE or thread sealant on fittings
2. HM2C and HM4C manifolds feature 1 inlet port and either 2 (HM2C) or 4 (HM4C) outlet ports and either 2 (HM2C) or 4 (HM4C) needle valves. See Figure 1 (**HM2C shown with protective caps on ports**).

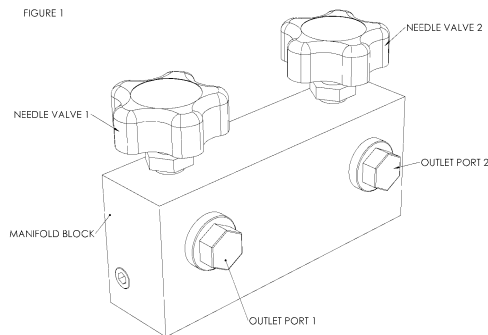

3. Connect hose from pump into the inlet Nipple. (Can be removed if required). See Figure 2.

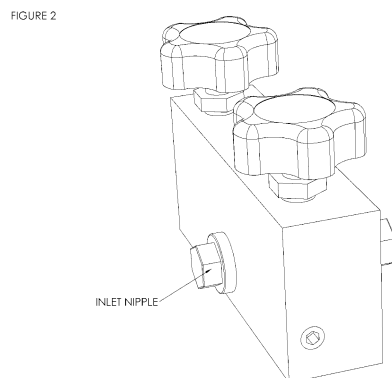

Prepared by:-	M.Davies	Approved by:-		Date: 09/09/14
REV NO:-	1			
ECO:-	4282			

- 4 Connect hoses from cylinders into outlet ports.
- 5 **Adjusting the knob on Needle Valve 1 will control the rate at which Hydraulic fluid exits Outlet Port 1.**

See Figure 3.

FIGURE 3

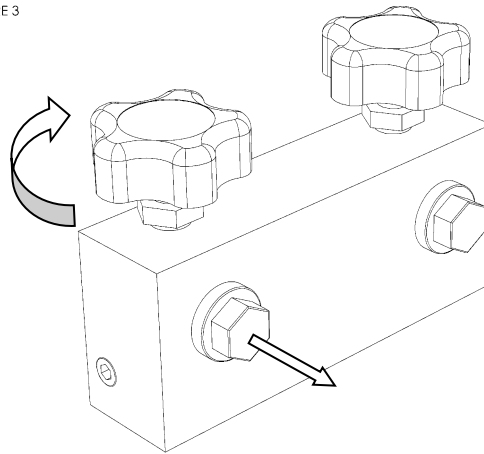

6. **Adjusting the knob on Needle Valve 2 will control the rate at which hydraulic fluid exits Outlet Port 2.**

See Figure 4.

FIGURE 4

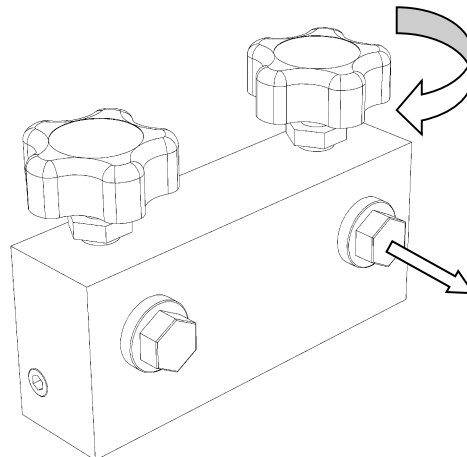

7. Needle valves 1 and 2 will also restrict oil flow under reverse flow. I.e from outlet to inlet.
8. When fully closed the Needle Valves maybe used to prevent reverse flow in load holding applications.

WARNING: DO NOT WORK UNDER A LOAD SUPPORTED ONLY BY HYDRAULIC MEANS.

CAUTION: WHEN NEEDLE VALVES ARE CLOSED OR SLIGHTLY OPEN, WITH THE PUMP DELIVERING OIL THE PUMP PRESSURE RELIEF VALVE MAY OPERATE WHICH WILL LEAD TO THE OIL TEMPRATURE RISE AFTER EXTENDED OPERATION.

Prepared by:-	M.Davies	Approved by:-		Date: 09/09/14
REV NO:-	1			
ECO:-	4282			

UK Head Office:

Hi-Force Limited
Prospect Way
Daventry
Northamptonshire
NN11 8PL
United Kingdom

Tel: + 44 1327 301000**Fax: + 44 1327 706555****Email: daventry@hi-force.com****Hi-Force Regional Offices:**

Hi-Force Australia Pty. Ltd
Rockingham
Australia
Tel: +61 8 9591 1288
Email: australia@hi-force.com

Hi-Force Caspian
Baku
Azerbaijan
Tel: +994 12 447 4100
Email: baku@hi-force.com

Hi-Force Hydraulics (Asia) S.B
Selangor
Malaysia
Tel: +603 5569 4209
Email: malaysia@hi-force.com

Hi-Force Nederland BV
Strijen
Netherlands
Tel: +31 78 6745488
Email: holland@hi-force.com

Hi-Force Hydraulics (Pty) Ltd
Midrand
South Africa
Tel: +27 11 314 0555
Email: south.africa@hi-force.com

Hi-Force FZCO
Dubai
United Arab Emirates
Tel: +971 4 815 0600
Email: dubai@hi-force.com

Hi-Force Hydraulics
Abu Dhabi
United Arab Emirates
Tel: +971 2 551 3100
Email: abu.dhabi@hi-force.com

Hi-Force Hydraulic Equipment
(Shanghai) Ltd. Co.
Shanghai, China
Tel: +86 21 6697 3010
Email: china@hi-force.com