

Minarc | 150, 151 150 VRD 120 AU, 150 AU

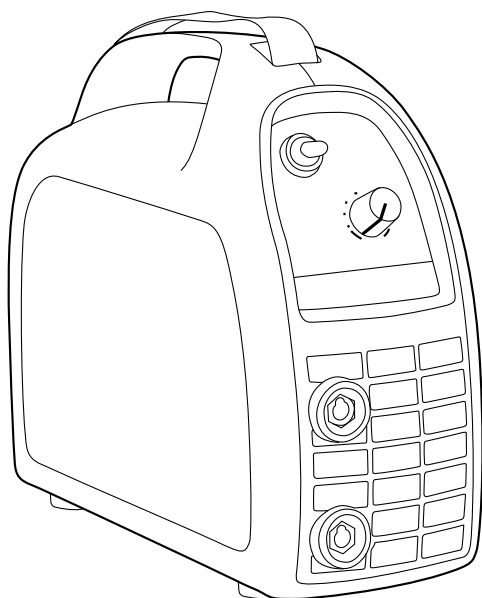

Operating manual • English *EN*

Käyttöohje • Suomi *FI*

Bruksanvisning • Svenska *SV*

Bruksanvisning • Norsk *NO*

Brugsanvisning • Dansk *DA*

Gebrauchsanweisung • Deutsch *DE*

Gebruiksaanwijzing • Nederlands *NL*

Manuel d'utilisation • Français *FR*

Manual de instrucciones • Español *ES*

Instrukcja obsługi • Polski *PL*

Инструкции по эксплуатации • По-русски *RU*

OPERATING MANUAL

English

CONTENTS

1.	PREFACE	3
1.1	General.....	3
1.2	Product introduction	4
2.	BEFORE YOU START USING THE UNIT	4
2.1	Unpacking.....	4
2.2	Placing the unit	4
2.3	Serial number.....	5
2.4	Main components.....	5
2.5	Distribution network.....	6
2.6	Connecting to power supply mains.....	6
2.7	Filler materials and equipment	6
3.	USE	7
3.1	Welding processes.....	7
	3.1.1 Manual Metal Arc welding (MMA)	7
	3.1.2 TIG welding.....	7
3.2	Operating functions	8
3.3	Welding selections	9
	3.3.1 Manual Metal Arc welding (MMA)	9
	3.3.2 DC TIG welding	9
3.4	Welding selections	10
	3.4.1 Earthing.....	10
	3.4.2 Welding.....	10
3.5	Storing.....	10
4.	MAINTENANCE	11
4.1	Daily maintenance.....	11
4.2	Troubleshooting	11
4.3	Disposal	12
5.	ORDERING NUMBERS	12
6.	TECHNICAL DATA	13

1. PREFACE

1.1 GENERAL

Congratulations on choosing the Minarc equipment. Used correctly, Kemppi products can significantly increase the productivity of your welding, and provide years of economical service.

This operating manual contains important information on the use, maintenance and safety of your Kemppi product. The technical specifications of the equipment can be found at the end of the manual.

Please read the manual carefully before using the equipment for the first time. For your own safety and that of your working environment, pay particular attention to the safety instructions in the manual.

For more information on Kemppi products, contact Kemppi Oy, consult an authorised Kemppi dealer, or visit the Kemppi web site at www.kemppi.com.

The specifications presented in this manual are subject to change without prior notice.

Important notes

Items in the manual that require particular attention in order to minimise damage and personal harm are indicated with the '**NOTE!**' notation. Read these sections carefully and follow their instructions.

1.2 PRODUCT INTRODUCTION

Kemppi Minarc is a manual metal arc welding machine, small in size, suitable for industry, site and repair welding. The unit uses one phase connection voltage and it is manufactured for two different mains voltages: 230 V (Minarc 150) and 110 V (Minarc 151).

Minarc tolerates a great fluctuation of input voltage and is thus suitable for work on sites using generator as well as to be used with long power cables. Inverter technology has been used when designing the unit. Power regulation in power source is done with IGBT transistors. Welding and earth cables are supplied with the unit. They are equipped with suitable connections for the unit electrode holder, earth clamps and connections.

Minarc can also be used for TIG welding. TIG arc is started by scratching. Ordering numbers of additional equipment for TIG welding can be found in chapter 5. Ordering numbers.

Minarc 150VRD is equipped with so called Voltage Reduction Device (VRD) function. VRD maintains open circuit voltage under 35 V.

Minarc 150AU and 120AU for mains voltages 240 V and with VRD function are on market only for Australia and New Zealand.

2. BEFORE YOU START USING THE UNIT

2.1 UNPACKING

The equipment is packed in durable packages, designed specially for them. Nevertheless, always before using the equipment, make sure it was not damaged during transportation. Also check that you have received what you ordered and that there are instructions for it. NOTE! The packaging material of the products is suitable for recycling.

2.2 PLACING THE UNIT

Place the unit on horizontal, solid and clean surface. Shield it from heavy rain and scorching sun. Make sure that cooling air circulates freely.

2.3 SERIAL NUMBER

Serial number of the unit is marked on the rating plate of the unit. The serial number makes it possible to trace product manufacturing series. You might need the serial number when placing spare parts orders or when planning maintenance.

2.4 MAIN COMPONENTS

Connect welding cable and earth cable to their connections on the power source. Mains cable and wall plug are already installed. (Note! Minarc 151 (110 V) is delivered without a plug).

Parts of the unit

1. Body of machine
2. Main power switch
3. Selector switch for welding process
4. Welding current regulator
5. Signal light machine 'ON', (VRD: 'VRD safe ON').
6. Signal light for overheating
7. Electrode holder and welding cable
8. Earth cable and clamp

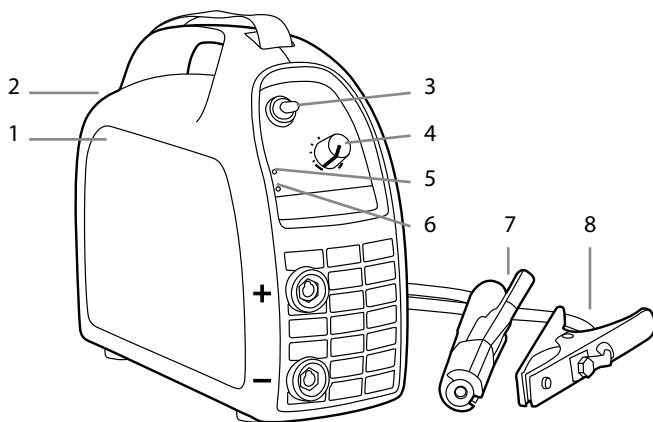

2.5 DISTRIBUTION NETWORK

All regular electrical devices without special circuits generate harmonic currents into distribution network. High rates of harmonic current may cause losses and disturbance to some equipment.

Minarc 150, 150 VDR, 120 AU, 150 AU

WARNING: This equipment does not comply with IEC 61000-3-12. If it is connected to a public low voltage system, it is the responsibility of the installer or user of the equipment to ensure, by consultation with the distribution network operator if necessary, that the equipment may be connected.

Does not apply to model Minarc 151.

2.6 CONNECTING TO POWER SUPPLY MAINS

The unit has a mains cable and a wall plug (Note! Minarc 151 (110V) is delivered without a plug). You can find fuse and cable sizes in the end of these instructions in Technical data.

2.7 FILLER MATERIALS AND EQUIPMENT

See also 2.4 Main components. You can use all electrodes intended for welding with DC. Suitable electrode sizes for the unit are listed in the end of these instructions in Technical data.

1. Use welding specifications given on electrode package.
2. Check that you have selected the correct welding process before starting to weld.
3. Check that welding cable and earth cable connections are tight. If a connection is slack, it will result in voltage drop that will cause the connection to heat.
4. Mount the electrode firmly in holder.

3. USE

NOTE! It is forbidden to weld in places where there is a danger of fire or explosion!

3.1 WELDING PROCESSES

3.1.1 Manual Metal Arc welding (MMA)

In manual metal arc (MMA) the welding filler material is melted from the electrode to the weld pool. Rate of welding current is selected on the basis of electrode size used and welding position. Arc forms between electrode tip and welding piece. The melting electrode coating forms gas and slag, which protects the weld pool. Slag solidified over the weld is removed after welding e.g. with a chipping hammer.

3.1.2 TIG welding

In DC TIG welding, the arc between tungsten electrode and the welding piece melts the welding piece, thus forming a weld pool. Arc and electrode are shielded by an inert shielding gas (Argon). If necessary, filler is used. Filler wire is fed into the weld pool from the outside of the arc. The filler wire and the welding current level are decided according to the base material type and thickness, joint form and welding position.

3.2 OPERATING FUNCTIONS

See also 2.4. Main components and 3.4. Welding selections.

1. Signal light, machine 'ON', (VRD: 'VRD safe ON')
2. Welding process selecting switch
3. Welding current adjuster
4. Signal light for overheating
5. Suitable electrodes; reference values for welding current

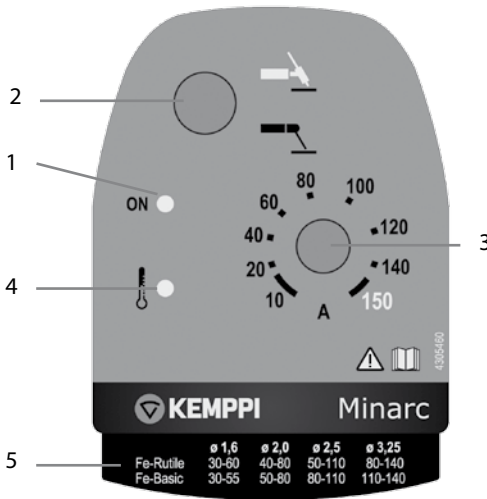

Main switch and signal light

When you turn the main switch to position I, signal light is lit and the unit is ready for welding. Signal light is always on, when the unit is connected to the mains and the main switch is in position I.

NOTE! Always start and stop the machine from the main switch, never use the plug as a switch!

Signal light VRD safe ON (1)

The machine is equipped with an OCV reduction circuit. The signal light is lit when the circuit is activated and the unit is in working order.

Welding process selector, MMA / TIG

Switch is used for selecting either MMA or TIG welding, depending on welding target.

VRD: When you have switched the unit to TIG welding, VRD is constantly active, thus reducing terminal voltage to 30 V. This facilitates arc cut-off when you stop welding.

Regulating welding current

Welding current rate is regulated steplessly with an adjusting potentiometer.

Signal light for overheating

A yellow signal light of overheating is lit, when thermostat has tripped due to the unit's overheating. Fan will cool the unit and after the signal light goes off, the unit is again ready for welding.

3.3 WELDING SELECTIONS

3.3.1 Manual Metal Arc welding (MMA)

Select welding parameters according to filler manufacturer's recommendations.

1. Select polarity (+ or -) of welding current cable and return current cable according to filler.
2. Select MMA welding with the switch .
3. Select suitable welding current by adjusting potentiometer.

3.3.2 DC TIG welding

Select welding parameters according to filler manufacturer's recommendations.

1. Connect TIG torch to - pole and earth cable to + pole
2. Select TIG welding with the switch .
3. Select suitable welding current by adjusting potentiometer.

3.4 WELDING SELECTIONS

NOTE! Welding fumes may be dangerous to your health, see that there is ample ventilation during welding! Never look at the arc without face shield made for arc welding! Protect yourself and your surroundings from the arc and hot spatter!

3.4.1 Earthing

If possible, always fix earth cable clamp directly on the welding piece.

1. Clean connection surface of earth clamp from paint and rust.
2. Connect the clamp carefully so that contact surface is as large as possible.
3. Finally check that the clamp sits tight.

3.4.2 Welding

See also 3.1. Welding processes and 3.4. Welding selections.

NOTE! It is recommended that you try welding and rate of welding current first on something else than the actual work piece.

You can start welding after having made the necessary selections. Arc is lit by scratching the welding piece with electrode. Length of arc is regulated by holding electrode tip at a suitable distance from welding piece. Suitable arc length is usually about half the diameter of the electrode core wire. When arc is lit move the electrode slowly forwards tilting it to appr. 10-15° pulling angle. If necessary, adjust current value.

Shielding gas is used in DC TIG welding. Your dealer will give you advice on choosing gas and equipment. Open the gas valve on the TTM 15V TIG torch. When gas starts to flow, arc is lit by lightly scratching work piece with the tip of the tungsten electrode. When arc is lit, its length is regulated by holding the tip of the tungsten electrode at a suitable distance from the work piece. Move the torch forwards from the starting point, usually in appr. 10-15° pushing angle forwards. If necessary, regulate current rate. Stop welding by lifting the torch off the welding piece and by closing the gas valve on the torch.

NOTE! Always fix the gas cylinder so that it stays steadily in upright position either in specially made wall rack or cylinder trolley. Always close the cylinder valve after having finished welding.

3.5 STORING

Store the unit in a clean and dry place. Shield it from rain, and in temperatures exceeding +25° C from direct exposure to sun.

4. MAINTENANCE

NOTE! Be careful when handling electrical cables!

In maintaining the unit, take into consideration the rate of use and the environment it is used in. When the unit is used properly and serviced regularly, you will avoid unnecessary disturbances in use and production.

4.1 DAILY MAINTENANCE

Perform the following maintenance daily:

- Clean electrode holder and TIG torch's gas nozzle. Replace damaged or worn parts.
- Check TIG torch's electrode. Replace or sharpen, if necessary.
- Check tightness of welding and earth cables connections.
- Check condition of mains and welding cables and replace damaged cables.
- See that there is enough space in front of and back of the unit for ventilation.

4.2 TROUBLESHOOTING

Problem	Cause
The main switch indicator will not light up	No electricity connected to the machine <ul style="list-style-type: none"> • Check the mains supply fuses. • Check the mains cable and plug.
Poor welding result	Several factors affect the welding quality. <ul style="list-style-type: none"> • Check that the earthing clamp is firmly attached, the point of attachment is clean and that the cable and its connectors are intact. • Check that the shielding gas flows out of the torch tip. • Check that the electric voltage is not irregular or too low/high.
Overheating indicator lit	The device has overheated. <ul style="list-style-type: none"> • Ensure that cooling air has unrestricted flow. • If the machine's duty cycle has been exceeded, wait for indicator to turn off. • Too low or high supply voltage.

If the machine's malfunction is not eliminated with these measures, contact KEMPPI service.

4.3 DISPOSAL



Do not dispose of electrical equipment with normal waste!

In observance of European Directive 2002/96/EC on waste electrical and electronic equipment, and its implementation in accordance with national law, electrical equipment that has reached the end of its life must be collected separately and taken to an appropriate environmentally responsible recycling facility.

The owner of the equipment is obliged to deliver a decommissioned unit to a regional collection centre, per the instructions of local authorities or a Kemppi representative. By applying this European Directive you will improve the environment and human health.

5. ORDERING NUMBERS

Item	Ordering number
Minarc 150 welding machine (includes earth- and welding cables)	6102150
Minarc 150 welding machine (Denmark) (includes earth- and welding cables)	6102150DK
Minarc 151 welding machine (includes earth- and welding cables)	6101151
Minarc 120AU welding machine (includes earth- and welding cables)	6102120AU
Minarc 150AU welding machine (includes earth- and welding cables)	6102150AU
Minarc 150VRD welding machine (includes earth- and welding cables)	6102150VRD
Earth cable and clamp	6184015
Welding cable and electrode holder	6184005
Carrying strap	9592162
Optional: TIG torch TTM15V, 4 m	6271432

6. TECHNICAL DATA

	Minarc 150, 150 VRD	Minarc 151
Connection voltage 1 ~ phase 50/60 Hz	230 V ± 15 %	110 V ± 15 %
Rated power at max. current		
35 % ED MMA	140 A/7.5 kVA	140 A/7.5 kVA
100 % ED MMA	100 A/5.1 kVA	100 A/5.1 kVA
35 % ED TIG	150 A/5.0 kVA	150 A/5.0 kVA
100 % ED TIG	110 A/3.3 kVA	110 A/3.3 kVA
Supply current		
35 % ED I_{1max}	27 A	59 A
100 % ED I_{1eff}	16 A	39 A
Connection cable	H07RN-F, 3G2.5 (2.5 mm ² , 3 m)	H07RN-F, 3G6 (6 mm ² , 2 m)
Fuse (delayed)	16 A	32 A
Welding range		
MMA	10 A/20.5 V – 140 A/25.6 V	10 A/20.5 V – 140 A/25.6 V
TIG	5 A/10 V – 150 A/16 V	5 A/10 V – 150 A/16 V
Welding current control	stepless	stepless
Open circuit voltage	85 V, (VRD 30 V)	85 V
Idle power	<10 W	<10 W
Power factor at 100% ED	0,60	0,60
Efficiency at 100% ED	80 %	80 %
Stick electrodes	ø 1.5–3.25 mm	ø 1.5–3.25 mm
External dimensions LxWxH	320x123x265 mm	320x123x265 mm
Weight without connection cable	4.0 kg	4.4 kg
Weight with connection cable	4.6 kg	5.2 kg
Temperature class	B (130° C)	B (130° C)
Operating temperature range	-20...+40° C	-20...+40° C
Storage temperature range	-40...+60° C	-40...+60° C
Degree of protection	IP23S	IP23S
EMC class	A	A
Norms	EN/IEC 60974-1	EN/IEC 60974-1
	EN/IEC 60974-10	EN/IEC 60974-10

	Minarc 120AU	Minarc 150AU
Connection voltage 1 ~ phase 50/60 Hz	240 V + 10 % ... - 20 %	240 V + 10 % ... - 20 %
Rated power at max. current		
ED MMA	50 %, 110 A/5.5 kVA	35 %, 140 A/7.5 kVA
ED MMA	100 %, 80 A/3.9 kVA	100 %, 100 A/5.1 kVA
ED TIG	50 %, 120 A/3.5 kVA	35 %, 150 A/5.0 kVA
ED TIG	100 %, 80 A/2.2 kVA	100 %, 110 A/3.3 kVA
Supply current		
35 % ED $I_{I_{max}}$	20 A	26 A
100 % ED $I_{I_{eff}}$	12 A	15 A
Connection cable	H07RN-F, 3G1.5 (1.5 mm ² , 3 m)	H07RN-F, 3G6 (2.5 mm ² , 2 m)
Fuse (delayed)	10 A	15 A
Welding range		
MMA	10 A/20.5 V – 110 A/24.4 V	10 A/20.5 V – 140 A/25.6 V
TIG	5 A/10 V – 120 A/15 V	5 A/10 V – 150 A/16 V
Welding current control	stepless	stepless
Open circuit voltage	30 V	30 V
Idle power	<30 W	<30 W
Power factor 100% ED	0.60	0,60
Efficiency 100% ED	80 %	80 %
Stick electrodes	Ø 1.5–2.5 mm	Ø 1.5–3.25 mm
External dimensions LxWxH	320x123x265 mm	320x123x265 mm
Weight without connection cable	4.0 kg	4.0 kg
Weight with connection cable	4.6 kg	4.6 kg
Temperature class	B (130 °C)	B (130 °C)
Operating temperature range	-20...+40 °C	-20...+40 °C
Storage temperature range	-40...+60 °C	-40...+60 °C
Degree of protection	IP23S	IP23S
EMC class	A	A
Norms	AS 1674.2	AS 1674.2
	AS/NZS 3652	AS/NZS 3652
	WTIA Tech note 22	WTIA Tech note 22
	EN/IEC 60974-1	EN/IEC 60974-1
	EN/IEC 60974-10	EN/IEC 60974-10

KEMPPI OY

Hennalankatu 39
PL 13
FIN-15801 LAHTI
FINLAND
Tel +358 3 899 11
Telefax +358 3 899 428
export@kemppi.com
www.kemppi.com

Kotimaan myynti:

Tel +358 3 899 11
Telefax +358 3 734 8398
myynti.fi@kemppi.com

KEMPPI SVERIGE AB

Box 717
S-194 27 UPPLANDS VÄSBY
SVERIGE
Tel +46 8 590 783 00
Telefax +46 8 590 823 94
sales.se@kemppi.com

KEMPPI NORGE A/S

Postboks 2151, Postterminalen
N-3103 TØNSBERG
NORGE
Tel +47 33 346000
Telefax +47 33 346010
sales.no@kemppi.com

KEMPPI DANMARK A/S

Literbuen 11
DK-2740 SKOVLUNDE
DANMARK
Tel +45 4494 1677
Telefax +45 4494 1536
sales.dk@kemppi.com

KEMPPI BENELUX B.V.

Postbus 5603
NL-4801 EA BREDA
NEDERLAND
Tel +31 765717750
Telefax +31 765716345
sales.nl@kemppi.com

KEMPPI (UK) Ltd

Martti Kemppi Building
Fraser Road
Priory Business Park
BEDFORD, MK44 3WH
UNITED KINGDOM
Tel +44 (0)845 6444201
Telefax +44 (0)845 6444202
sales.uk@kemppi.com

KEMPPI FRANCE S.A.S.

65 Avenue de la Couronne des Prés
78681 EPONE CEDEX
FRANCE
Tel +33 1 30 90 04 40
Telefax +33 1 30 90 04 45
sales.fr@kemppi.com

KEMPPI GmbH

Otto-Hahn-Straße 14
D-35510 BUTZBACH
DEUTSCHLAND
Tel +49 6033 88 020
Telefax +49 6033 72 528
sales.de@kemppi.com

KEMPPI SPÓŁKA Z O.O.

Ul. Borzymowska 32
03-565 WARSZAWA
POLAND
Tel +48 22 7816162
Telefax +48 22 7816505
info.pl@kemppi.com

KEMPPI AUSTRALIA PTY LTD.

13 Cullen Place
P.O. Box 5256, Greystanes NSW 2145
SMITHFIELD NSW 2164
AUSTRALIA
Tel. +61 2 9605 9500
Telefax +61 2 9605 5999
info.au@kemppi.com

OOO KEMPPI

Polkovaya str. 1, Building 6
127018 MOSCOW
RUSSIA
Tel +7 495 739 4304
Telefax +7 495 739 4305
info.ru@kemppi.com

ООО КЕМПИ

ул. Полковая 1, строение 6
127018 Москва
Tel +7 495 739 4304
Telefax +7 495 739 4305
info.ru@kemppi.com

KEMPPI, TRADING (BEIJING) COMPANY, LIMITED

Room 420, 3 Zone, Building B,
No.12 Hongda North Street,
Beijing Economic Development Zone,
100176 Beijing
CHINA
Tel +86-10-6787 6064
+86-10-6787 1282
Telefax +86-10-6787 5259
sales.cn@kemppi.com

肯倍贸易 (北京) 有限公司
中国北京经济技术开发区宏达
北路12号
创新大厦B座三区420室
(100176)
电话 : +86-10-6787 6064
+86-10-6787 1282
传真 : +86-10-6787 5259
sales.cn@kemppi.com

KEMPPI INDIA PVT LTD

LAKSHMI TOWERS
New No. 2/770,
First Main Road,
KAZURA Gardens,
Neelangarai,
CHENNAI - 600 041
TAMIL NADU
Tel +91-44-4567 1200
Telefax +91-44-4567 1234
sales.india@kemppi.com