

Allgemeine Daten | general data

Netzanschluss	power supply	400 / 3 / 50	V / ph / Hz
Netzabsicherung	main fuse	6	A
Steuerspannung	control voltage	24	VAC
Netzzuleitung	main supply cable	4G1.5	
Netto Gesamtmasse ca.	weight	33	kg

Elektrokettenzug | electric chain hoist

Bauform	type	030/52	
Traglast	working load	500	kg
Strangzahl	no. of load falls	1	
Hubhöhe	lifting height	20	m
Hubgeschwindigkeit(en)	lifting speed(s)	8,0	m/min
Triebwerksgruppe	duty group	1Bm/M3	FEM/ISO
Einschaltdauer	duty rate	40	%
Schaltungen/Stunde	starts per hour	240	S/h
IP Schutzart	IP protection class	IP 55	
Motortyp	motor type	KLOR 63G2	
Motorleistung	motor power	0,70	kW
Nennstrom	nominal current	1,60	A
Motordrehzahl	motor speed	2700.	1/min
cos phi	cos phi	0,88	

Fahrwerk | trolley

Typ	type		
Traglast	working load		kg
Fahrgeschwindigkeit(en)	travelling speed(s)		m/min
IP Schutzart	IP protection		
Motortyp	motor type		
Motorleistung	motor power		kW
Nennstrom	nominal current		A
Motordrehzahl	motor speed		1/min
cos phi	cos phi		

Abmessungen in mm | dimensions in mm

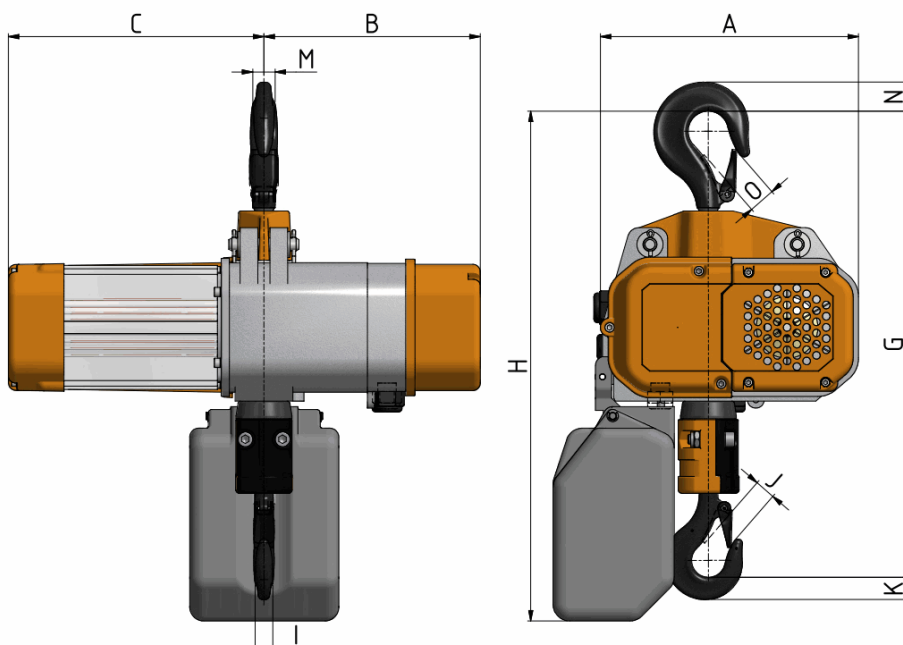

A	221
B	192
C	220
G	437
H	662
I	15
J	20
K	19
M	19
N	24
O	22